

## AN74

### Solar Street Lighting application with ZXLD1374

Silvestro Russo – September 2010

#### Introduction

Energy efficiency and sustainability are more and more at the top of policymakers' agenda. A way to reduce power consumption and CO<sub>2</sub> impact while maintaining the safety standards of the roads is to use solar powered solar street lighting systems.

Interest in solar lighting systems, and particularly street lighting, is rising also for the possibility to install them in remote areas such as rural areas in less developed countries.

Solar street lighting systems generally consist of a solar panel able to deliver about 90W, a battery charge controller, a set of batteries at 12V and a Boost driver to control the current in the LEDs, as shown in figure 1.

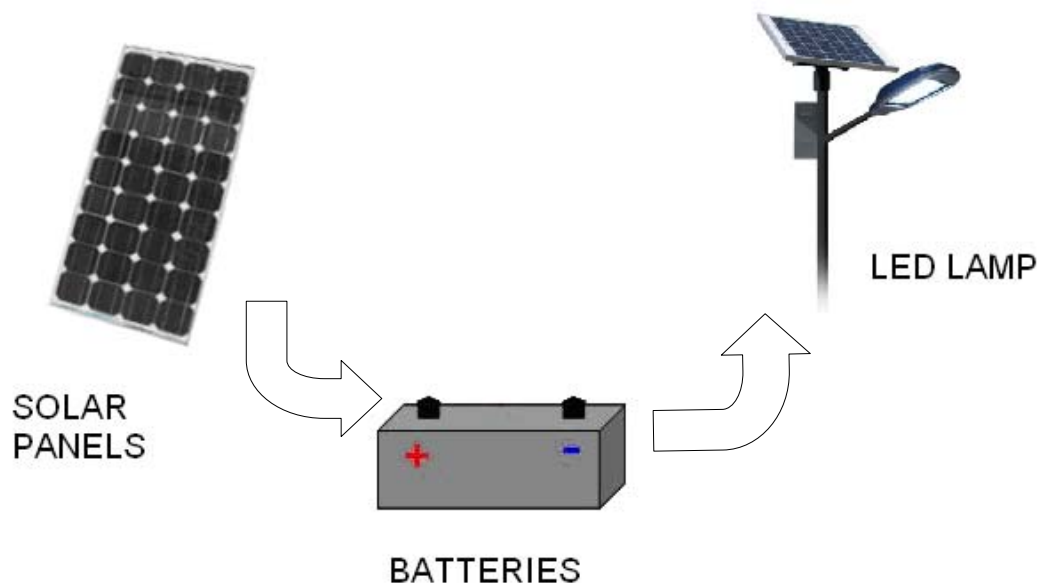

Figure 1: Solar street lighting system

#### ZXLD1374 Device description

The ZXLD1374 is an LED driver IC with an internal MOSFETs to drive high current LEDs. It is a multi-topology driver enabling it to efficiently control the current through series connected LED. The multi-topology enables it to operate in Buck, Boost and Buck-boost configurations.

The 60V capability coupled with its multi-topology flexibility enables it to be used in a wide range of applications and drive up to 15 LEDs in series.

The ZXLD1374 is a modified hysteretic controller using a patent pending control scheme providing high output current accuracy in all three modes of operation. High accuracy dimming is achieved through dc dimming and high frequency PWM dimming.

The ZXLD1374 uses two pins for fault diagnosis. A flag output highlights a fault presence, while the multi-level status pin gives further information on the specific fault.

## ZXLD1374 for solar street lighting

Street lighting applications are modular since they need to adapt to different light output requirements.

The circuit using the ZXLD1374 is designed to drive a single string of 12 series connected LEDs from a 12V battery for solar street lighting applications.

In particular, in this note we are going to focus on a design of a lighting system having 4200lm on target from a single fitting.

To this end, the procedure to calculate the number of strings (modules) required for our target applications are as in the following paragraphs.

Assuming to use 90lm/W LEDs and lenses with 90% optical efficiency and a further 20% of lumen losses due to thermal derating of the LEDs at high temperature, a string of 12LEDs @ 350mA is able to deliver approximately 898lm.

Lumen output per string =  $90\text{lm/W} * 0.9 * (1 - 0.2) * (12 * 3.3\text{V} * 350\text{mA}) = 898\text{lm}$

Since the requirement for solar street lighting systems is to have 4200lm on target from a single fitting, the number of strings required is 5.

The total power dissipation will depend also on the type of LEDs being used:

$$\text{If } V_F = 3.3\text{V} \rightarrow P_{LED} = 3.3\text{V} * 0.35\text{A} = 1.15\text{W}$$

The total output power for 5 strings of 12 series LEDs is:

$$P_{LED-TOT} = 5 * 12 * P_{LED} = 69\text{W}$$

Since the ZXLD1374 can achieve 91% of efficiency in this application the total power consumption is:

$$P_{TOT-MAX} = P_{LED-TOT} / \text{Min - Efficiency} = 69 / 0.91 = 75.8\text{W}$$

Therefore to total power consumption of a system of 5 strings of 12 LEDs in series is about 75W, compatible with the power that a standard solar panel used in street lighting applications can currently deliver.

## Solar Street Lighting - System design

In this section the system design procedure is outlined according to the schematic shown in figure 2.

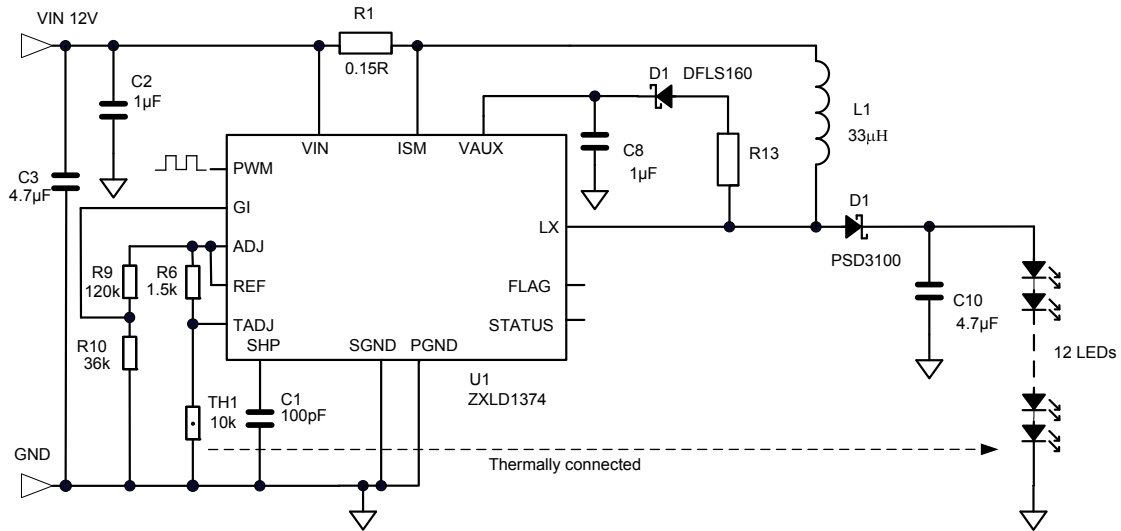

**Figure 2: Circuit schematic**

The specifications for each string of the module are:

VIN = 12V (Nominal)

VINMIN = 9V (minimum)

VINMAX = 15V (maximum)

I<sub>LED</sub> = 350mA

V<sub>LED</sub> = 3.3V

V<sub>LEDs</sub> = 12 \* V<sub>LEDs</sub> = 40V

The LED current have been set according to the following considerations:

Calculate the max duty cycle: 
$$D_{MAX} = \frac{V_{LEDS} - V_{IN MIN}}{V_{LEDS}} = \frac{40 - 9}{40} \approx 0.77$$

Calculate the GI pin ratio as 
$$\frac{R_{10}}{(R_9 + R_{10})} \approx 1 - D_{MAX} \approx 0.23$$

Calculate the sense resistor as: 
$$R_1 = \frac{R_{10}}{(R_9 + R_{10})} \frac{225mV}{I_{LED}} \approx 150m\Omega$$

This component dimensioning with allow the device to operate safely in worst case condition since:

$$I_{LED} = 350mA$$

$$I_{\text{COIL}} = \frac{I_{\text{LED}}}{1 - D_{\text{MAX}}} = 1.52\text{A}$$

$$V_{\text{RS}} = I_{\text{COIL}} * R_1 = \frac{I_{\text{LED}} * R_1}{1 - D} = 228\text{mV}$$

While in nominal condition this will result in:

$$I_{\text{LED}} = 350\text{mA}$$

$$I_{\text{COIL}} = \frac{I_{\text{LED}}}{1 - D} = 1.17\text{A}$$

$$V_{\text{RS}} = I_{\text{COIL}} * R_1 = \frac{I_{\text{LED}} * R_1}{1 - D} = 175\text{mV}$$

### Input capacitor

The input capacitor can be selected using the following formula:

$$C_{\text{IN}} = \frac{\Delta I_{\text{COIL-PP}}}{8 * f_{\text{SW}} * \Delta V_{\text{IN-PP}}}$$

Where:

- $\Delta I_{\text{COIL-PP}}$ , the ripple on the coil current, is 40% of worst case current  $I_{\text{COIL}} = 1.52\text{A}$
- $\Delta V_{\text{IN-PP}}$ , the ripple on the input voltage, is set at 100mV
- $f_{\text{SW}}$ , the switching frequency, is 350kHz in nominal conditions

$$C_{\text{IN}} = C_3 = \frac{\Delta I_{\text{COIL-PP}}}{8 * f_{\text{SW}} * \Delta V_{\text{IN-PP}}} = \frac{2 * 0.2 * 1.52}{8 * 350\text{k} * 100\text{m}} \approx 2.2\mu\text{F}$$

To minimize power supply interaction a 200% larger capacitance  $C_3$  of approximately 4.7  $\mu\text{F}$  is used, therefore the actual  $\Delta V_{\text{IN-PP}}$  is much lower.

In addition to this, a capacitor  $C_2$  of 1 $\mu\text{F}$  placed close to the VIN pin is used to filter the supply signal on VIN pin in order to guarantee high level of accuracy in the sensed current.

### Output capacitor

An output capacitor is required to limit interference and provide energy to the load when the freewheeling diode is reverse biased during the first switching subinterval. The output capacitor is chosen to provide a desired current ripple of the LED current (usually recommended to be less than 40% of the average LED current).

$$C_{\text{OUTPUT}} = \frac{D * I_{\text{LED}}}{f_{\text{SW}} * r_{\text{LED}} * \Delta I_{\text{LED-PP}}}$$

where:

- $\Delta I_{\text{LED}}$  is the ripple of the LED current, set at 10%  $\rightarrow 35\text{mA}$
- $f_{\text{sw}}$  is the switching frequency (From graphs and calculator)

- $r_{LED}$  is the dynamic resistance of the LEDs string (N times the dynamic resistance of the single LED - from the datasheet of the LED manufacturer).

$$C_{OUTPUT} = C_{10} = \frac{D * I_{LED}}{f_{SW} * r_{LED} * \Delta I_{LED-PP}} = \frac{0.7 * 350mA}{350kHz * 12 * 350m\Omega * 35mA} \approx 4.7\mu F$$

The output capacitor should be chosen to account for derating due to temperature and operating voltage. It must also have the necessary RMS current rating. The minimum RMS current for the output capacitor is calculated as follows:

$$I_{C_{OUTPUT-RMS}} = I_{C_{10-RMS}} = I_{LED} \sqrt{\frac{D_{MAX}}{1-D_{MAX}}} = 0.35 \sqrt{\frac{0.77}{1-0.77}} = 0.64A$$

Ceramic capacitors with X7R dielectric are the best choice due to their high ripple current rating, long lifetime, and performance over the voltage and temperature ranges.

## Thermal Feedback

In order to improve the system reliability and lifetime, it is advisable to reduce the LED current at high temperatures, for example starting to reduce the current from 80°C.

The ZXLD1374 offers a simple way to realize a LED temperature thermal feedback using a resistor and NTC connected to the TADJ pin, as shown in the schematic below.

Here a simple procedure to design the thermal feedback circuit in this example:

- 1) Temperature threshold  $T_{threshold} = 80^{\circ}C$
- 2)  $TH1 = 10k\Omega @ 25^{\circ}C$  and  $\beta_{eta} = 3500 \rightarrow TH1 = 1.5k\Omega @ 80^{\circ}C$
- 3)  $R_6 = TH1 @ T_{threshold} = 1.5k\Omega$

## System Diagnostic

The ZXLD1374 has two pins, FLAG and STATUS, which provide the diagnostic function if this is required by the application. In this way, the system can be used in conjunction with a controlling section that can receive the diagnostic signals to protect the system and highlight any unwanted behavior.

The FLAG/STATUS outputs provide a warning of extreme operating or fault conditions. FLAG is an open-drain logic output, which is normally high resistance, but switches low resistance to indicate that a warning, or fault condition exists. STATUS is a DAC output, which is normally high (4.5V), but switches to a lower voltage to indicate the nature of the warning/fault.

For more information about the conditions monitored, the method of detection and the nominal STATUS output voltage it is recommended to refer to the datasheet of the ZXLD1374.

In figure 3, it can be found the true table of the diagnostic section in terms of FLAG voltage and STATUS voltage levels in relation to the different warning/fault conditions.

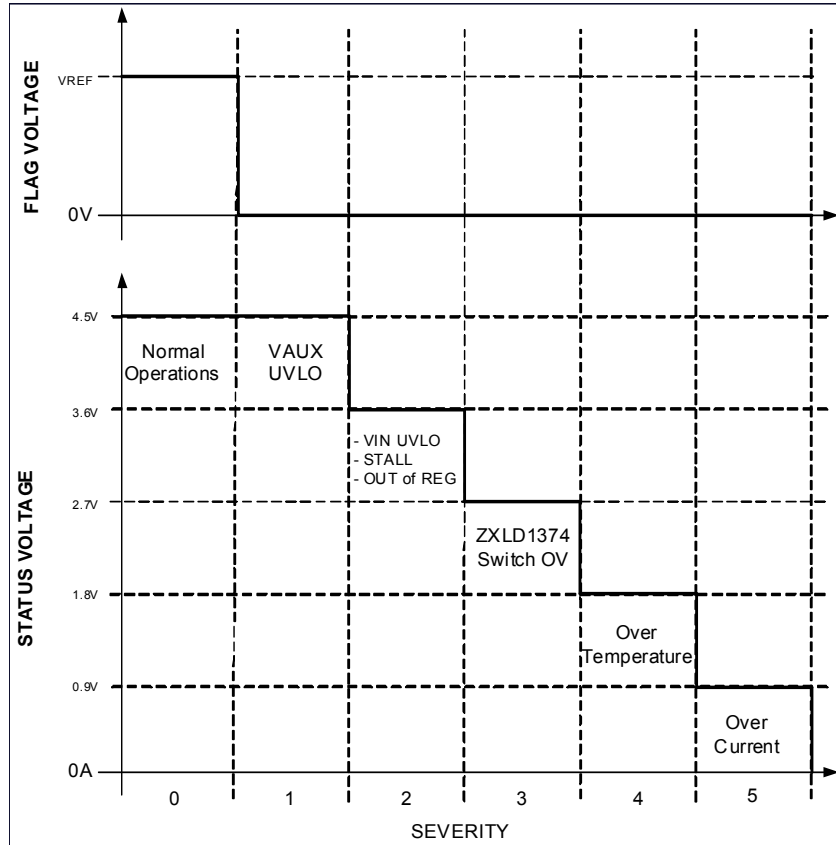

**Fig 3: Status levels and FLAG signal**

In the event of more than one fault/warning condition occurring, the higher severity condition will take precedence. E.g. 'Excessive coil current' and 'Out of regulation' occurring together will produce an output of 0.9V on the STATUS pin.

## DIMMING

Dimming function, both DC and PWM dimming, can be used to reduce the light output and energy consumption during night hours when the need to have illuminated roads is lower. For example dimming the light output from 100% to 50% from 1am to 6am can be accomplishing using a simple microcontroller.

### PWM dimming

The ZXLD1374 has a dedicated PWM dimming input that allows a wide dimming frequency range from 100Hz to 1kHz with 1000:1 resolution; however higher dimming frequencies can be used, at the expense of dimming dynamic range and accuracy.

Typically, for a PWM frequency of 1kHz, the error on the current linearity is lower than 4%; in particular the accuracy is better than 1% for PWM from 5% to 100% (figure 4).

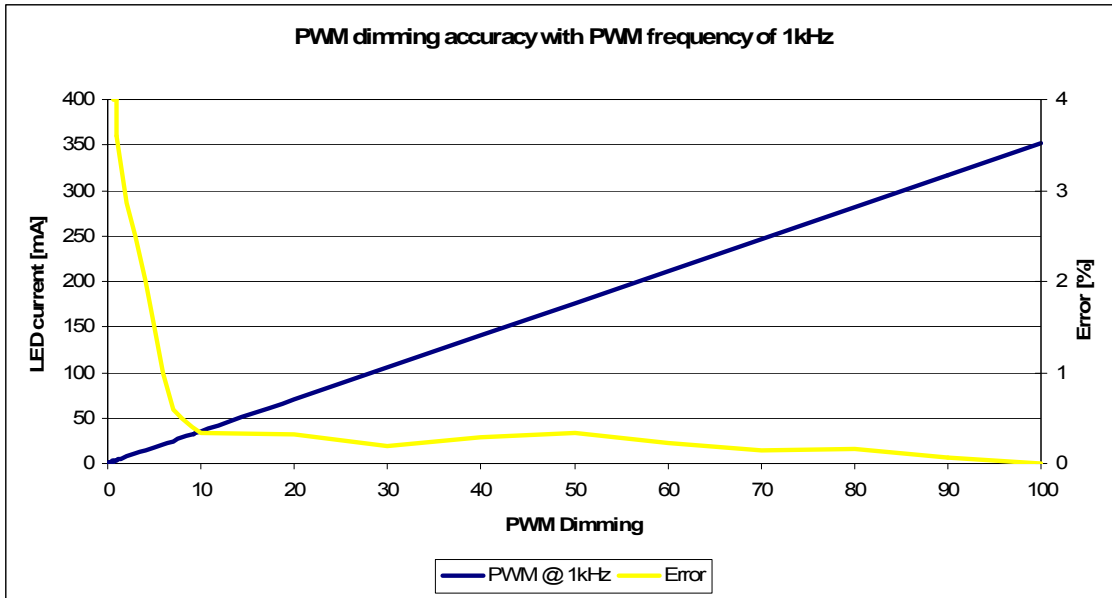

Figure 4: PWM dimming

**DC dimming**

DC dimming is performed modifying the voltage on the adjust input. When the ADJ pin is connected to REF, it sets the output current to its 100% nominal value. Driving the ADJ pin with dc voltage ( $125\text{mV} < V_{\text{ADJ}} < 2.5\text{V}$ ) it is possible to adjust output current from 10% to 200% of set value. The ADJ pin has an internal clamp that limits the internal node to less than 3V. This provides some failsafe should they get overdriven.

The following section will graphically display the LED current as a function of the voltage on the ADJ pin.

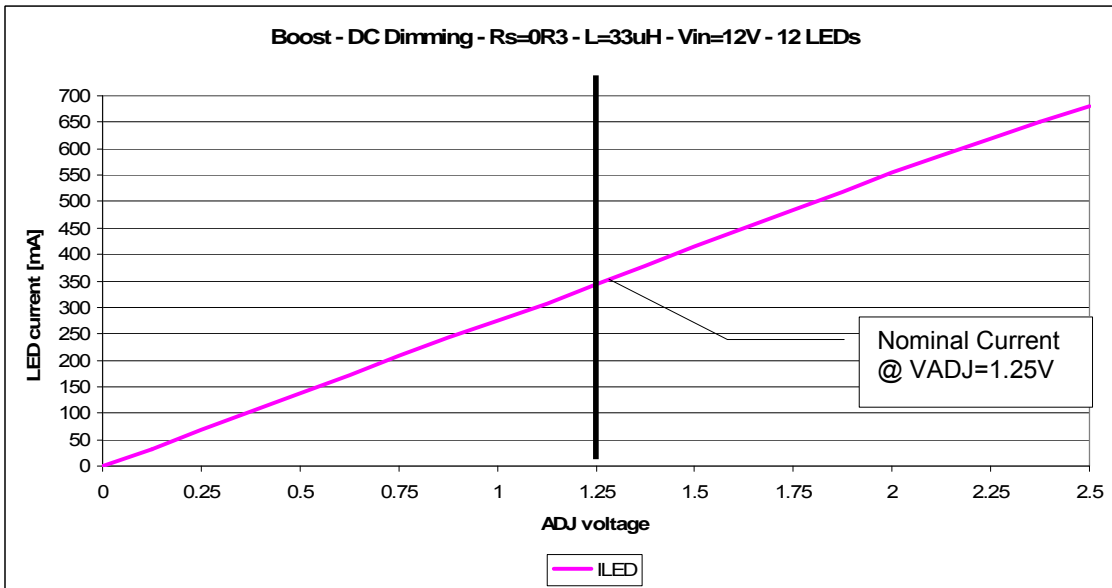
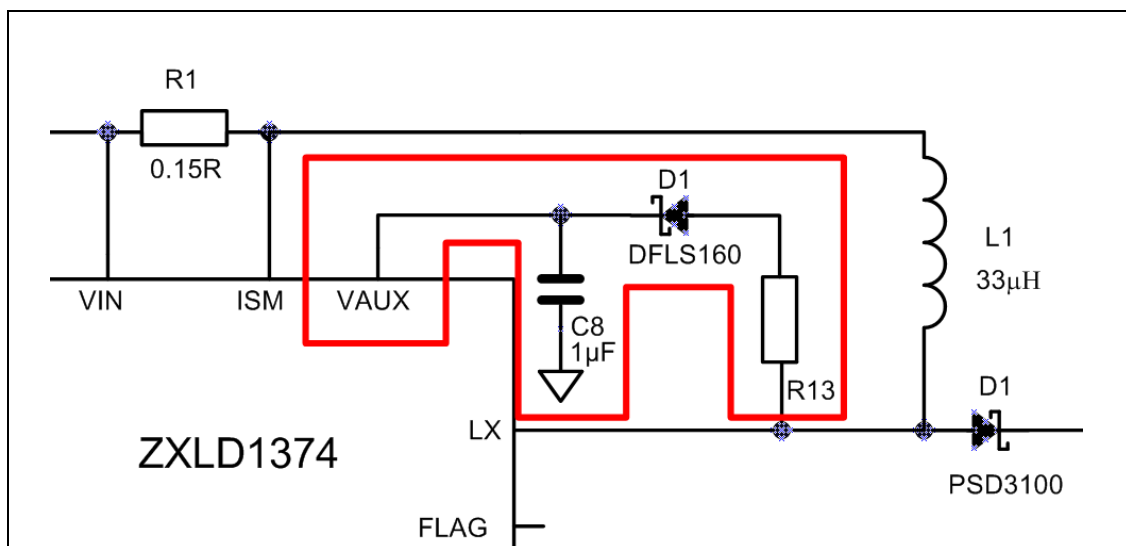

Figure 5: PWM dimming

The dimming function can be also used to compensate for the lost of lumen output of the LEDs with time; this can be realized for example increasing the LED current of 1% every 2 years to compensate of a 10% lost of lumen efficiency over 20 years. It is worth noting that in this case the circuit components need to be designed taking into account the progressive increase in LED current over time.

## Bootstrap circuit

The solar street lighting module proposed in this document requires the use of a bootstrap circuit connected to Vaux. The bootstrap circuit will guarantee that the gate of the internal switch is fully enhanced in all conditions.



**Figure 6: Bootstrap circuit**

The bootstrap circuit is realized adding a reservoir capacitor, C8, able to supply an average 10mA current during the 'turn on' of the internal MOSFET.

In addition of the capacitor C8, a current limiting resistor R13=1k $\Omega$  and a blocking diode D2 (DFSL160) are required.

Using a capacitor of 1 $\mu$ F (C8) will guarantee the best trade-off between VAUX supply needs and LED current accuracy. In fact, using 1 $\mu$ F capacitor, VAUX pin supply will require few mA of current from the LED current and only during the first switching cycles. In normal operation the current sunk from the LED current to supply Vaux will be negligible. This will improve the overall current accuracy of the system.



## Results

The performances of the systems are outlined in table 1 and in figure 7 and 8.

They display a level of efficiency generally higher than 91% and a current regulation of around 1% over the whole range of the input voltages.

**Table 1: Test data**

Parameter		Reading		
VIN	Load	Vout	I <sub>LED</sub>	Efficiency
12	12 LEDs	40V	350mA	91%

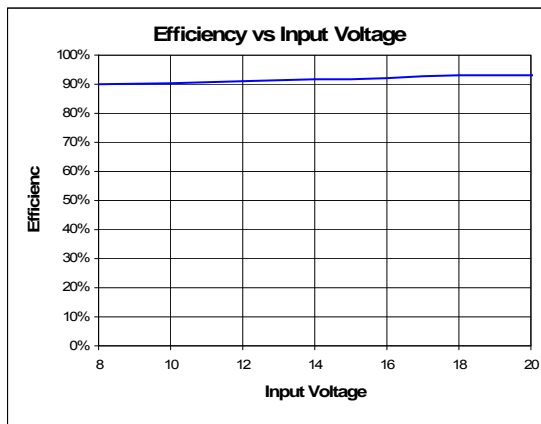

**Figure 7: LED driver system efficiency**

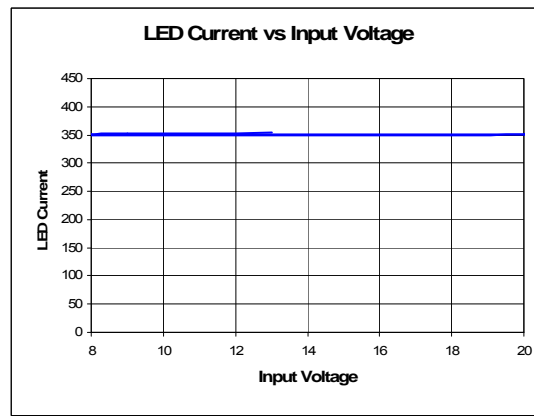

**Figure 8: LED driver current regulation**

The BOM in table 2 and the PCB layout in figures 9 and 10, complete the tools needed to design a solar street lighting system using the ZXLD1374.

**Table 2: BOM**

Item	Designator	Description	Part N	Manufacturer
1	U1	Multi – Topology LED driver	ZXLD1374	DIODES Inc
2	D1	3A – 100V Schottky diode in PowerDI5 package	PSD3100	DIODES Inc
3	D2	1A – 60V Schottky diode in PowerDI123	DFLS160	DIODES Inc
4	L1	33uH 4.2A	744770933	Würth Elektronik
5	C1	100pF COG 0805 capacitor	Generic	
6	C2, C8	1uF – 50V – 1206 Ceramic capacitors	C1206X105K5RAC	KEMET
7	C3, C10	4.7uF – 50V – 1210 Ceramic capacitors	C1210X475K5RAC	KEMET
8	R1	0R15 1210 500mW sense resistor	Generic	
9	R6	1.5k Ω 0805 resistor	Generic	
10	R9	120kΩ 0805 resistor	Generic	

11	R10	36k $\Omega$ 0805 resistor	Generic	
12	R13	1k $\Omega$ 1206 resistor	Generic	
13	TH1	10k $\Omega$ NTC 1206 Beta = 3500	Generic	

## PCB layout

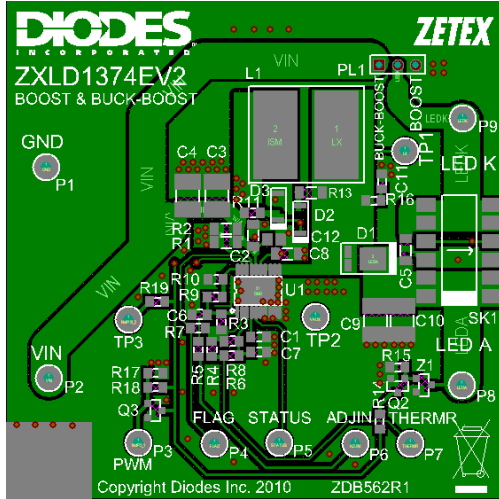

Figure 9: Top Layer

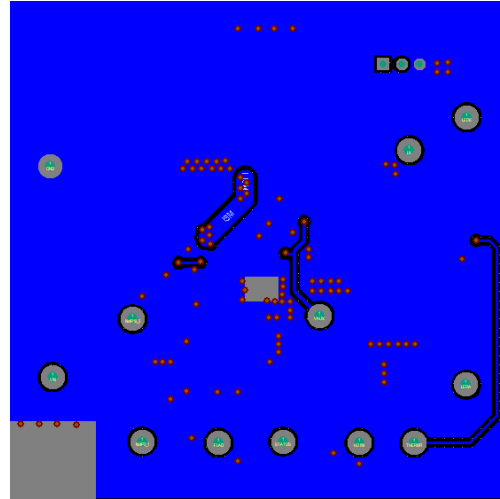

Figure 10: Bottom Layout

For more considerations on the layout and further support in the design phase please refer to the datasheet and the calculator available on the website [www.diodes.com](http://www.diodes.com)

## Conclusion

This application note provides a simple tool to design a solar street lighting system using the ZXLD1374 LED driver. It provides a high level of efficiency as well as LED current control over the whole range of input voltages. Moreover the design note explains how to design a system with thermal feedback, allowing derating of the LED current at high temperature. This feature will allow the designer to get the maximum from a LED lighting system improving the life time of the system and reducing the total cost of ownership. Dimming and Diagnostic functions are also explained to improve system flexibility and reliability on all the conditions a solar street lighting application can encounter.

## IMPORTANT NOTICE

DIODES INCORPORATED MAKES NO WARRANTY OF ANY KIND, EXPRESS OR IMPLIED, WITH REGARDS TO THIS DOCUMENT, INCLUDING, BUT NOT LIMITED TO, THE IMPLIED WARRANTIES OF MERCHANTABILITY AND FITNESS FOR A PARTICULAR PURPOSE (AND THEIR EQUIVALENTS UNDER THE LAWS OF ANY JURISDICTION).

Diodes Incorporated and its subsidiaries reserve the right to make modifications, enhancements, improvements, corrections or other changes without further notice to this document and any product described herein. Diodes Incorporated does not assume any liability arising out of the application or use of this document or any product described herein; neither does Diodes Incorporated convey any license under its patent or trademark rights, nor the rights of others. Any Customer or user of this document or products described herein in such applications shall assume all risks of such use and will agree to hold Diodes Incorporated and all the companies whose products are represented on Diodes Incorporated website, harmless against all damages.

Diodes Incorporated does not warrant or accept any liability whatsoever in respect of any products purchased through unauthorized sales channel. Should Customers purchase or use Diodes Incorporated products for any unintended or unauthorized application, Customers shall indemnify and hold Diodes Incorporated and its representatives harmless against all claims, damages, expenses, and attorney fees arising out of, directly or indirectly, any claim of personal injury or death associated with such unintended or unauthorized application.

Products described herein may be covered by one or more United States, international or foreign patents pending. Product names and markings noted herein may also be covered by one or more United States, international or foreign trademarks.

## LIFE SUPPORT

Diodes Incorporated products are specifically not authorized for use as critical components in life support devices or systems without the express written approval of the Chief Executive Officer of Diodes Incorporated. As used herein:

- A. Life support devices or systems are devices or systems which:
1. are intended to implant into the body, or
  2. support or sustain life and whose failure to perform when properly used in accordance with instructions for use provided in the labeling can be reasonably expected to result in significant injury to the user.
- B. A critical component is any component in a life support device or system whose failure to perform can be reasonably expected to cause the failure of the life support device or to affect its safety or effectiveness.

Customers represent that they have all necessary expertise in the safety and regulatory ramifications of their life support devices or systems, and acknowledge and agree that they are solely responsible for all legal, regulatory and safety-related requirements concerning their products and any use of Diodes Incorporated products in such safety-critical, life support devices or systems, notwithstanding any devices- or systems-related information or support that may be provided by Diodes Incorporated. Further, Customers must fully indemnify Diodes Incorporated and its representatives against any damages arising out of the use of Diodes Incorporated products in such safety-critical, life support devices or systems.

Copyright © 2010, Diodes Incorporated

[www.diodes.com](http://www.diodes.com)